

Item-No. 235112

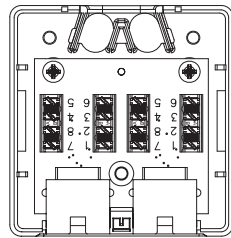

SCALE 1/2

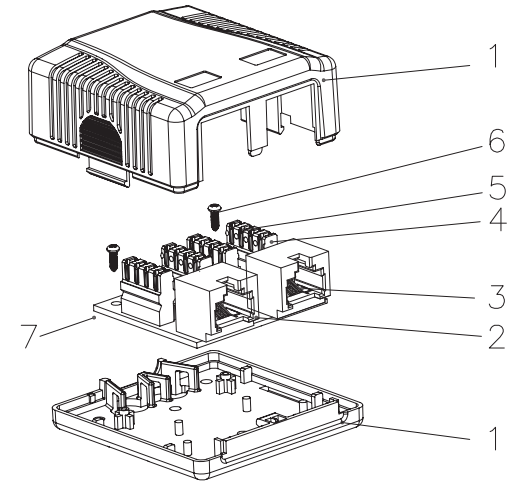
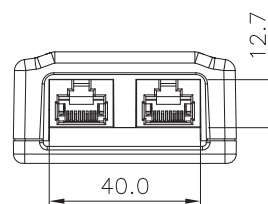
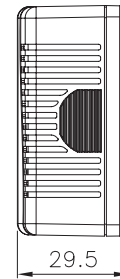
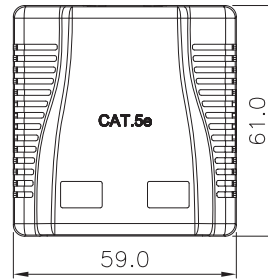

SCALE 1/2

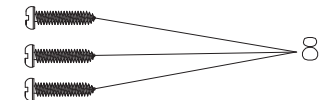

SCALE 1/2

Specification :

Material :

1. Top & Bottom Case : ABS, UL 94V-0.
2. RJ45 Jack Housing : PBT+15%GF, UL 94V-0.
3. RJ45 Jack contact material & finished :
 - 3-1. Phosphor Bronze with 50-60 micro-inch Nickel plated.
 - 3-2. Contact area : Min. 3mm 50 micro-inch Gold plated.
4. IDC Housing : PC+5%GF, UL 94V-2.
5. IDC Terminal :
 - 5-1. Phosphor Bronze with 50-60 micro-inch Tin plated.
 - 5-2. 110 & Krone tool compatible.
 - 5-3. Suitable for 22-26 AWG stranded and solid wire.
6. Screw : M2.0x6.0xφ3.3mm.
7. PCB : FR4, 2Layer, UL 94V-0.
8. Screw : M3.5x16.0xφ6.0mm.

Performance :

- a. The IDC color codes combine two wirings of T568A & T568B.
- b. Operation temperature : -10°C to 65°C.
- c. Durability :
 - c-1. Jack : 750 cycles Plug-Jack mating and unmating test, insertion cycles at 20 cycles/minute max. Contact resistance test per 100 cycles.
 - c-2. IDC : Max. 200 punching times.
- d. The Cat.5e performance is in compliance with the ANSI/TIA/EIA 568 B.2 standard.

GENERAL TOLERANCE OF DIMENSIONS
 X.XXX ±0.005
 X.XX ±0.05
 X.X ±0.1



Outlet UTP Cat.5e, surface mounted, 2-Port

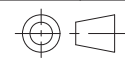

DRAWING NO.			
DRAWING CLASSIFICATION	S	SHEET	1 OF 1

