

FILE AMEND NOTE	DATE	REV.
ORIGINALITY EDITION	2013/07/08	A/0

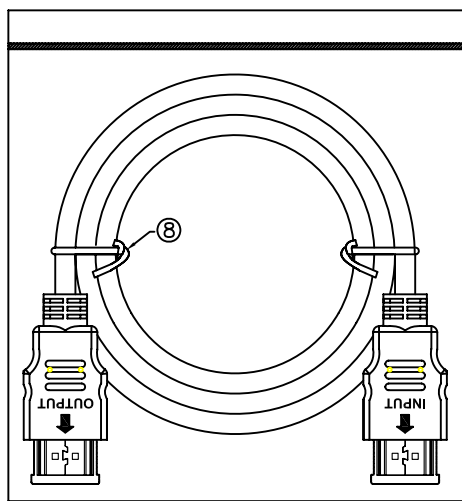

PIN OUT

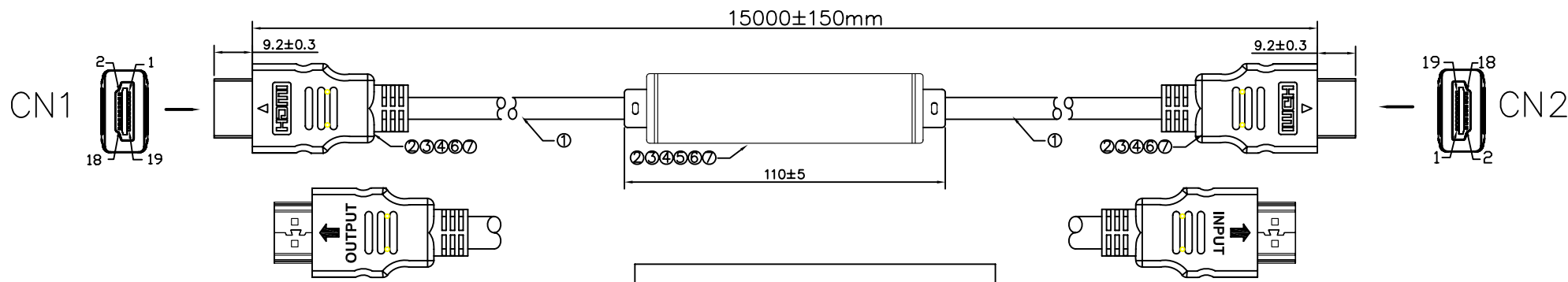
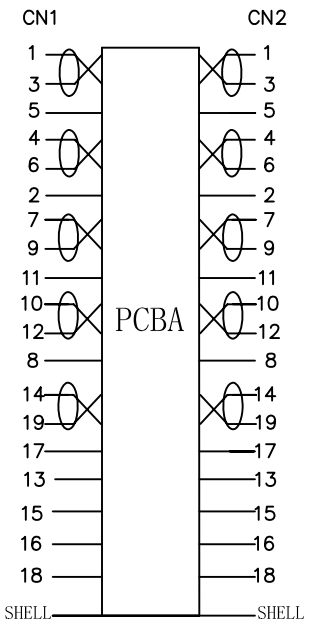

- NOTE:
- Cable Electrical test:
    - 100% open short & miss wire test;
    - Insulation resistance:DC 300V 10M ohm;
    - Contact resistance: 15 ohm;
  - RoHS COMPLIANT
  - PRINT WORD:HIGH SPEED HDMI<sup>®</sup> CABLE WITH ETHERNET

MATERIAL LIST:

⑨	PE BAG	PE BAG:L280*W260*t0.06mm	1	PCS
⑧	MINI TIN	PE MINI TIN BLACK L=150mm	2	PCS
⑦	OVER MOLDING	45P PVC BLACK	50	g
⑥	INNER MOLDING	LD-PE	20	g
⑤	SHELL	The Shell For Aluminium Alloys, And Size For L:89mm	1	PCS
④	PCBA	19P/F-F And The IC On PCB.	1	SET
③	H. S. T	∅0.6*16mm BLACK	4	PCS
2	HDMI	19P/M SOLDER TYPE, The Pin Gold Plating, the shell for Gold Plating	2	PCS
①	CABLE	HDMI CABLE: (1/0.32BC*1P+0.30CCS+AL)*5P+1/0.32BC*1C+1/0.30CCS*3C+AL +D1/0.32BC+B112/0.12AL-MG OD:7.3mm JACKET:BLACK.	1	PCS
NO.	PARTS NAME	SPECIFICATION DESCRIPTION	QT'Y	UNIT

DRAW NO.		PRODUCT NAME		HDMI 19P/M - HDMI A/M	
				MAPE	
CUSTOMER		ITEM NO.		119358	
				APPOBY	
DRAWNBY		UNTT		MM	
				Page	

